

Matching Plug

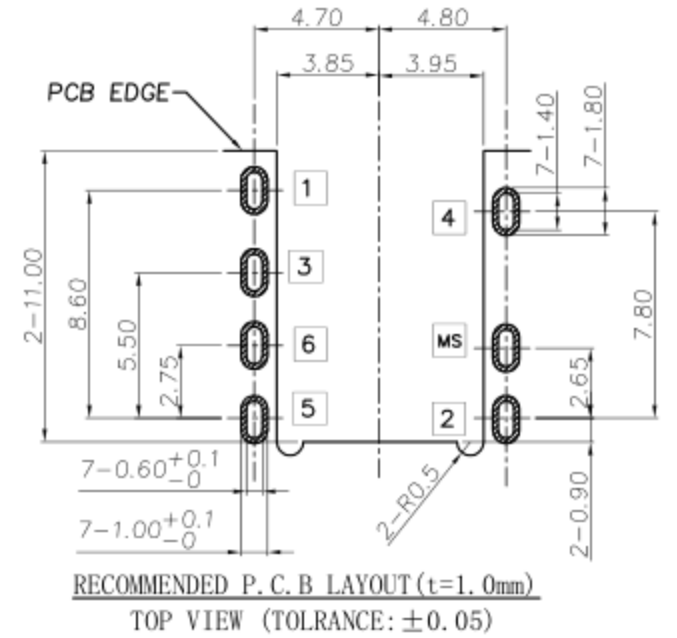
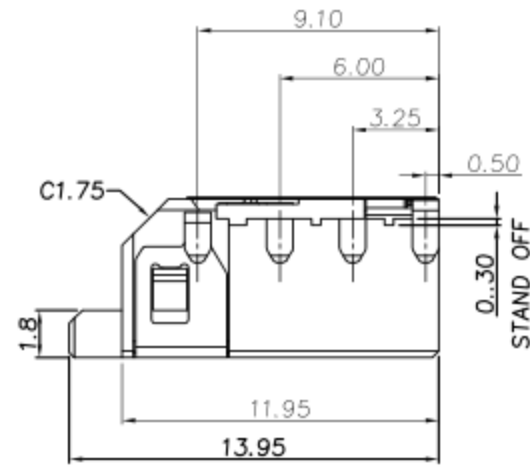
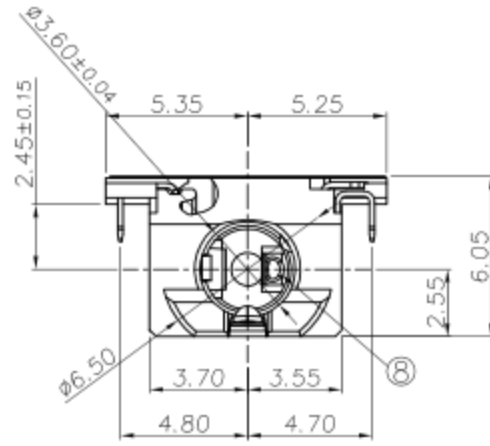
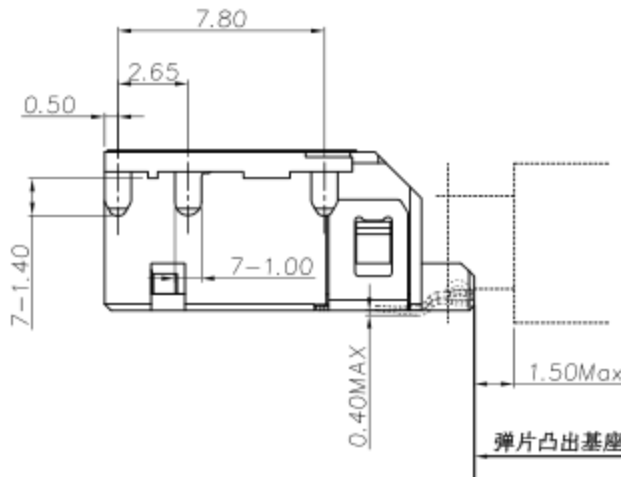
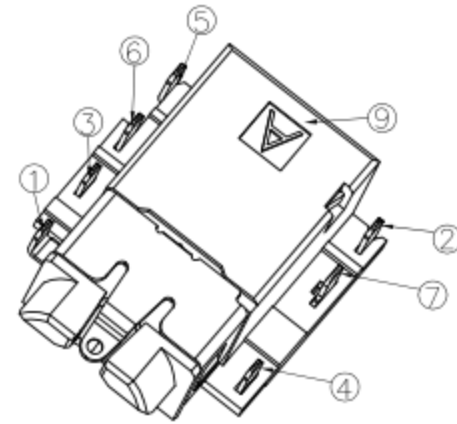
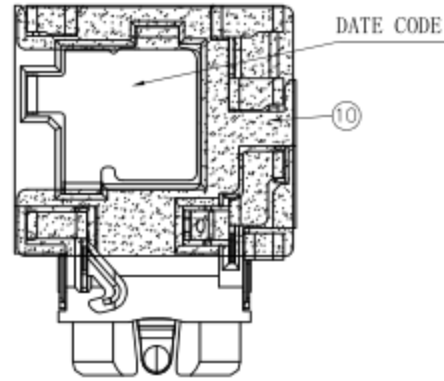
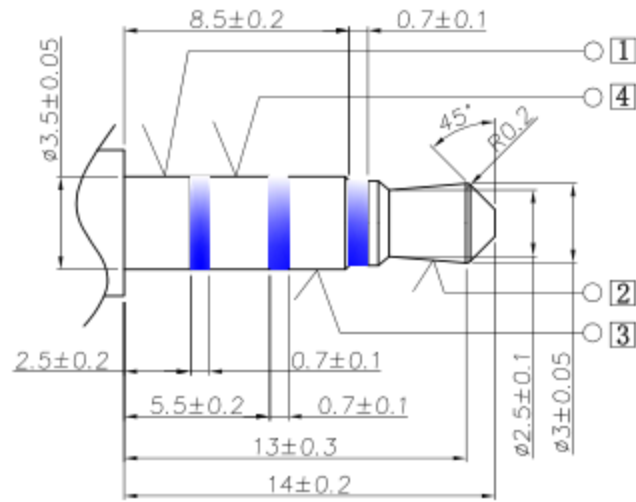

SPECIFICATION:

1. Electrical characteristics

- 1-1. Current rating: DC 0.5A max.
- 1-2. Voltage rating: DC 30V.
- 1-3. Contact resistance: $50\text{m}\Omega$ max.
- 1-4. Insulation resistance: $100\text{M}\Omega$ min. at 500V DC.
- 1-5. Withstanding voltage: 500V AC for 1 minute.

2. Mechanical characteristics

- 2-1. Life test: 5000 cycles min,
- 2-2. Mating force: $3\sim 30\text{N}$,
Unmating force: $3\sim 30\text{N}$.

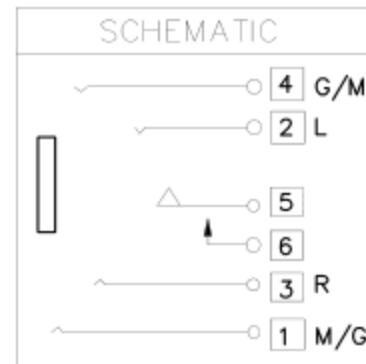
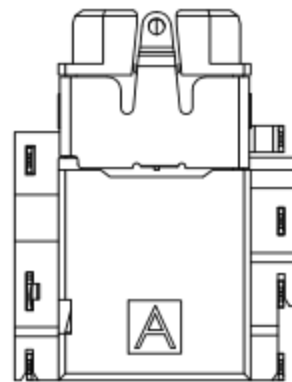

NO.	DESCRIPTION	QTY	MATERIAL	REMARK
⑩	Mylar	1	Kapton	Yellow
⑨	Housing	1	PA10T R630NH	Black
⑧	Insulator	1	PA10T R630NH	Black
⑦	Shell	MS	C5210R-EH, 0.20t	Nickel Plated
⑥	Shunt terminal	⑥	C5210R-EH, 0.20t	G/F On Contact Gold Flash On Solder Tail Area, Nickel UnderPlated
⑤	Transfer Spring	⑤	C5210R-EH, 0.20t	
④	Ring spring	④	C5210R-EH, 0.20t	
③	Ring spring	③	C5210R-EH, 0.20t	G/F On Contact Area Tin Plating on Solder Tail Area, All over Nickel Plated
②	Tip spring	②	C5210R-EH, 0.20t	
①	Earth spring	①	C5210R-EH, 0.20t	

ECN NO.	REV	DATE	DESCRIPTION	CHANGE	APPRO.	GENERAL TOLERANCE UNLESS OTHERWISE NOTED	SCALE: 3:1	UNIT:mm	A4
						Angle $\pm 2^\circ$	DESIGN	刘伟	2020. 11. 18
						.x ± 0.35	CHECK		
	A-1	2021. 01. 12	客户要求STAND OFF高度由0.25修改至0.30	刘伟	余军	.xx ± 0.25	APPROVAL		
	A-0	2020. 11. 18	NEW	刘伟	余军	.xxx ± 0.15			

东莞市高迪电子有限公司

CUSTOMER DRAWING	TITLE:	MODEL NO.	FILE NO.
	$\phi 3.5\text{mm}$ PHONE JACK	PJR-D3264B-ABK7AS02L-RH	Q/DY. QW-001A-XXXX